

# Above Ground Fire Hydrant with Storz Outlet

- Tamperproof
- Inlet: - 100mm Female BSP Thread or Male BSP Thread
- Outlet: - 100mm Storz Outlet
- Body Material: - SG Iron and FBE Coated
- Spindle: - Stainless Steel 410
- Spindle Square: - 16mm (SABS1128)
- Gate: EPDM encapsulated Cast Iron with 'Easy Seal' Spherical shape, seals drip tight at low torque
- Seat: Ductile Iron
- Working Pressure: 20 Bar
- Flow rates: In Excess of 1200 litres per minute (SABS 1128)
- Hand Wheels and "T" Keys are available
- Weight – 8.5 Kg

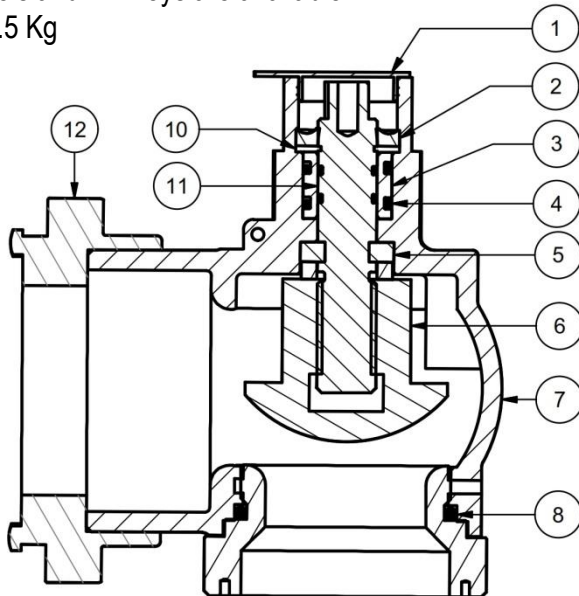

Material List		
Item	Part	Material
1	Spindle Cap	Plastic
2	Circlip - Heavy Duty AS-24	Stainless Steel
3	Bush	Brass
4	O-Ring	NBR
5	Thrust Collar	Brass
6	Gate	EPDM Encapsulated Cast Iron
7	Body Above Ground	S.G Iron - Gr420/12
8	O-Ring	NBR
9	Seat	Nickel Plated Ductile Iron
10	Spindle	Stainless Steel - Gr420 S29
11	O-Ring	NBR
12	Storz 100mm	Aluminium