

Top Access Underground Fire Hydrant

- 80mm Inlet Flanged Multi Drilled
- 65mm Bolt on outlet, London Round or London Vee
- PN 20 Bar Rated
- Right Hand or Left Hand Closing
- Weight: 13Kg
- Flow rates: In Excess of 1200 litres per minute (SABS 1128)
- Gate: EPDM encapsulated Ductile Iron with 'Easy Seal'
- Spherical shape, seals drip tight at low torque
- Seat: Ductile Iron FBE Coated
- Body: Ductile Iron FBE Coated

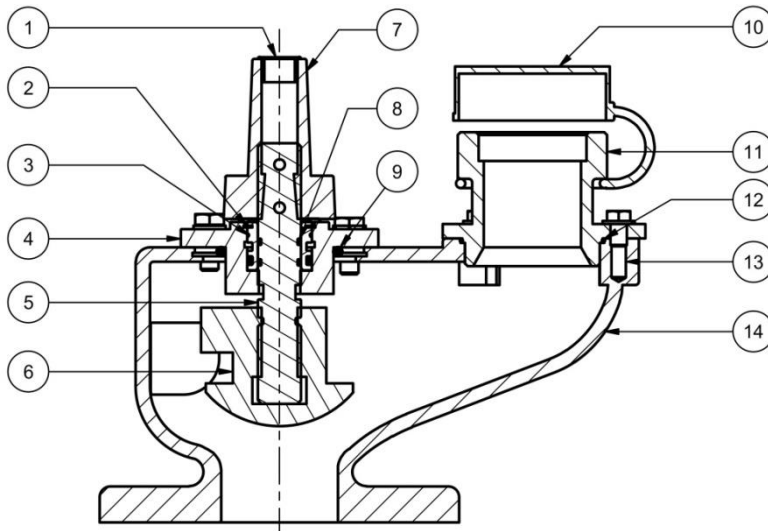

Part List		
Item	Parts Name	Material
1	Cap Top Cap	Plastic
2	Circlip	Stainless Steel - Grd 410
3	Bush	Brass - DZR
4	Bonnet	SG Iron - Grd 420/12
5	Spindle	Stainless Steel - Grd 420
6	Gate	SG Iron EPDM totally Encapsulated
7	Cap Top	SG Iron - Grd 420/12
8	Thrust Washer	Brass - DZR
9	Thrust Collar	Brass - DZR
10	Dust Cap	NBR
11	Hydrant Outlet	Stainless Steel - Grd 420
12	O-Ring	NBR
13	Cap Screw	HT Steel - Grd 8.8
14	Body	SG Iron - Grd 420/12